

## INSULATED STAINLESS STEEL AQUATEMP™ HOT CABINET MODEL H-137-WSUA-12C

### FEATURES AND BENEFITS:

- Fully insulated hot cabinet keeps prepared foods at serving temperatures.
- Powerful, yet efficient, heating system maintains the right combination of heat and humidity to properly hold products.
- 2000 Watts of heat holds food at up to 200°F (93°C).
- AquaTemp system allows you to hold with humidity by adjusting individual thermostats; regulate humidity levels by controlling air temperature to 180°F (82°C); lowering air temperature allows for humidity up to 95%.
- Internal frame in body and doors plus reinforced internal base maintains structural rigidity.
- 304 stainless steel construction throughout for ease of cleaning.
- Smooth interior coved corners prevent food particles/grease buildup.
- Safety-conscious anti-microbial latches protect against spreading germs.
- Field reversible insulated Dutch doors prevent temperature loss. Silicone door gaskets for proper seal.
- Standard with right hand hinging; left hand hinging available upon request.
- High temperature ceramic magnetic latches for "easy open"; twist-lock catch keeps door securely closed.
- Recessed push/pull handles on both sides prevents damage to walls; allows easy maneuvering.
- Twelve sets of stainless steel wire universal angles accommodate a large variety of pan sizes on adjustable 1-1/2" centers.
- Integral drip trough on front keeps traffic area dry, safer.
- Heavy duty 5" swivel casters, two with brakes. Provides mobility when fully loaded.



H-137-WSUA-12C



### ACCESSORIES and OPTIONS (Available at extra cost):

- Tempered Glass Door Windows
- Lock Hasp
- Extra Universal Angles
- 208 or 240 Volt Service
- Food Safe Digital Thermometer

See page B-20 for accessory details.

# H-137-WSUA-12C

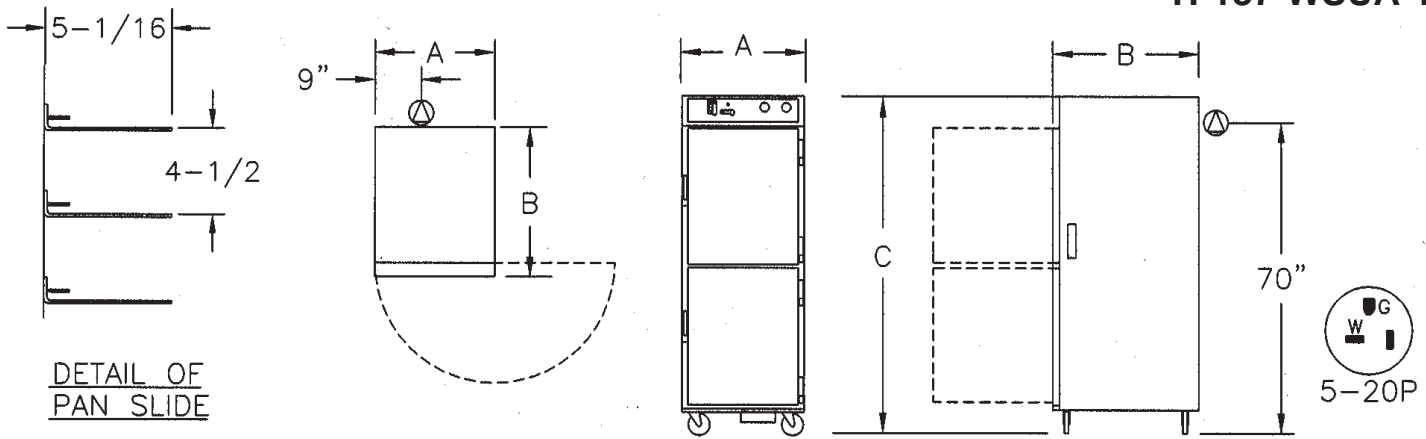

CRES COR MODEL NO.	PAN			DIM "A"	DIM "B"	DIM "C"	INSIDE DIMENSIONS				WEIGHT ACT.
	CAP/ ANGLES	SIZE		WIDTH	DEPTH	HEIGHT	WIDTH	DEPTH	HEIGHT		
H-137-WSUA-12C	12 SETS	SEE NOTE BELOW	IN	28-1/4	33-5/8	73	21-3/4	27-1/2	58	LBS	298
			MM	720	855	1855	555	700	1475	KG	135

NOTES: 1. Pan sizes 22" x 20" (560 x 510) Roast & Bake Pans, 10" x 20" (255 x 510) Roast & Bake Pans, 18" x 26" (460 x 660) Bun Pans, 14" x 18" (355 x 460) Service Trays, 12" x 20" (305 x 510) Steam Table Pans.  
Refer to Pan Size Chart at end of section.

2. When ordering bumpers, add 2" to overall dimensions.

ALL CONSTRUCTION IS RIVETED, WELDED AND FINISHED.

## CABINET:

- Body: 22 ga. 304 stainless steel.
- Reinforcement: Internal framework of 18 ga. 304 stainless steel.
- Insulation: Fiberglass, thermal conductivity (K factor) is .23 at 75°F. 1-1/2" in doors, top, base; 2" in sidewalls.
- Air tunnel: 22 ga. 304 stainless steel; lift-out type, mounted on back.
- Push/pull handles (2): 5" vertical; recessed.
- Interior coved corners.

## BASE:

- One piece construction, .125 aluminum.
- Drip trough: Formed 18 ga. stainless steel mounted to front of cabinet; removable drip pan.
- Casters: 5" dia., swivel, modulus tires, 1-1/4 wide, load cap. 250 lbs. each, temp. range -45°/+180°F. Delrin bearings. Front casters equipped with brakes.

## DUTCH DOORS:

- Field reversible.
- Formed 22 ga. 304 stainless steel.
- Latches: Chrome plated steel, high temperature ceramic magnetic type.
- Transport Latches.
- Hinges: Heavy duty chrome plated steel.
- Gaskets: Perimeter type, silicone.
- Pan stops: Embossed.

## PAN SLIDES:

- Stainless steel wire universal angles (.306 dia.), mounted on lift-out posts.
- Spaced on 4-1/2" centers; adjustable on 1-1/2" centers.

## HOT UNIT COMPONENTS:

- Top mounted; removable with tools.
- Thermostat (holding): Solid state, room ambient to 200°F (93°C).
- Thermostat (humidity): Solid state, room ambient to 95%.
- Power Light
- Switch: rocker type.
- Power cord: Permanent, 10 ft., 12/3 ga.
- Heater: 2000 Watts for holding.
- Blower motor.
- Vent fan.
- Thermometer.
- Water pan: 4 gallons; 16 ga. 304 stainless steel with 1850 Watt heater for humidity.

## POWER REQUIREMENTS:

- 2000 Watts, 120 Volts, 60 Hz., single phase, 16 Amps., 20 Amp. service.

## SHORT FORM SPECIFICATIONS

Cres Cor Insulated AquaTemp Hot Cabinet Model H-137-WSUA-12C. Cabinet 22 ga. 304 stainless steel; stainless steel internal frame. (12) sets stainless steel wire universal angles for multiple pan sizes, adjustable spacing every 1-1/2". Field reversible Dutch doors, 22 ga. 304 stainless steel. Fiberglass insulation in sides 2"; doors, top, base 1-1/2". Interior coved corners. 2000 Watt, 120 Volt power unit; adjustable heat and humidity. One piece insulated base, .125 aluminum. 5" swivel modulus casters, Delrin bearings. Load capacity 250 lbs. each. 2 year parts warranty. Provide the following accessories: \_\_\_\_\_ . NSF, CSA-US, CSA-C, ENERGY STAR Qualified.



5925 Heisley Road • Mentor, OH 44060-1833  
Phone: 877/CRESCOR • Fax: 440/350-7267  
www.crescor.com

© Crescent Metal Products, Inc. 2010 All rights reserved.

*In line with its policy to continually improve its products, CRES COR reserves the right to change materials and specifications without notice.*

Litho in U.S.A.